

SN

SUN PROTECTION



Facade-mounted aluminium solar shading devices. To be installed on facades, on mullion-transom curtain walls.

SUN PROTECTION

Facade-mounted aluminium solar shading devices. To be installed on facades, on mullion-transom curtain walls.

Shading devices available in sizes: 100, 150, 158, 200, 250, 270, 300 and 350 mm. Fixed brackets – angle of inclination from 0°, 14°, 15°, 30°, 45°, 60 to 75°. Option of vertical and horizontal installation.

Option of direct installation on the building facade.

The installation is possible not only on straight walls, but also in places where the facade changes in direction.

All elements of aluminium shading devices are characterised by high strength and resistance to weather conditions.

Facade-mounted solar shading devices change the look of facade by providing it with an interesting and modern character. They provide a great potential in creating a modern and vivid external appearance of the building. Sun Protection devices combine durability, thermal and optical comfort as well as aesthetics and functionality.

Wide range of colours – RAL palette (Qualicoat 1518), texture colours, Aliplast Wood Colour Effect (wood-like colours), Aliplast Loft View – colours imitating stone surfaces (Qualideco PL-0001), anodized colour (Qualanod 1808), bi-colour.

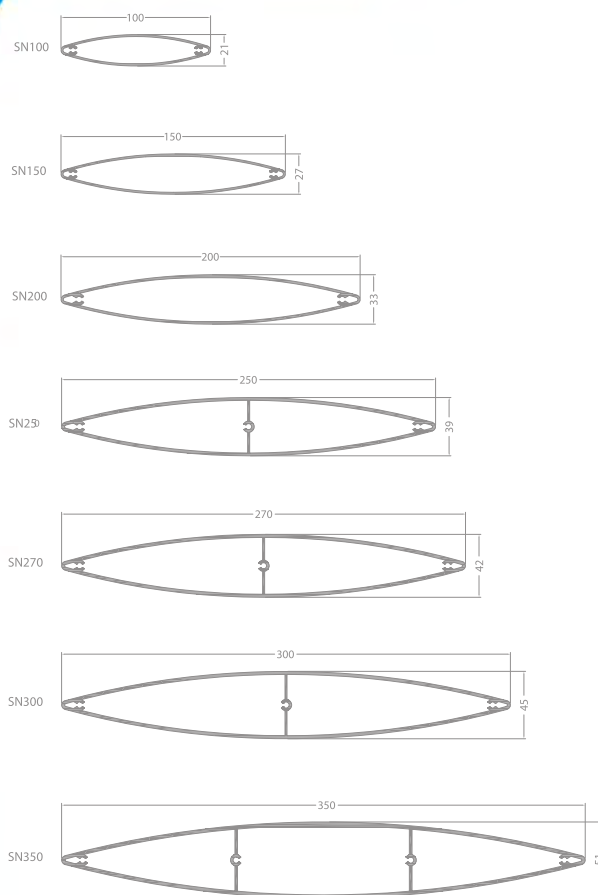

sample of dimensions and angles for Sun Protection panels

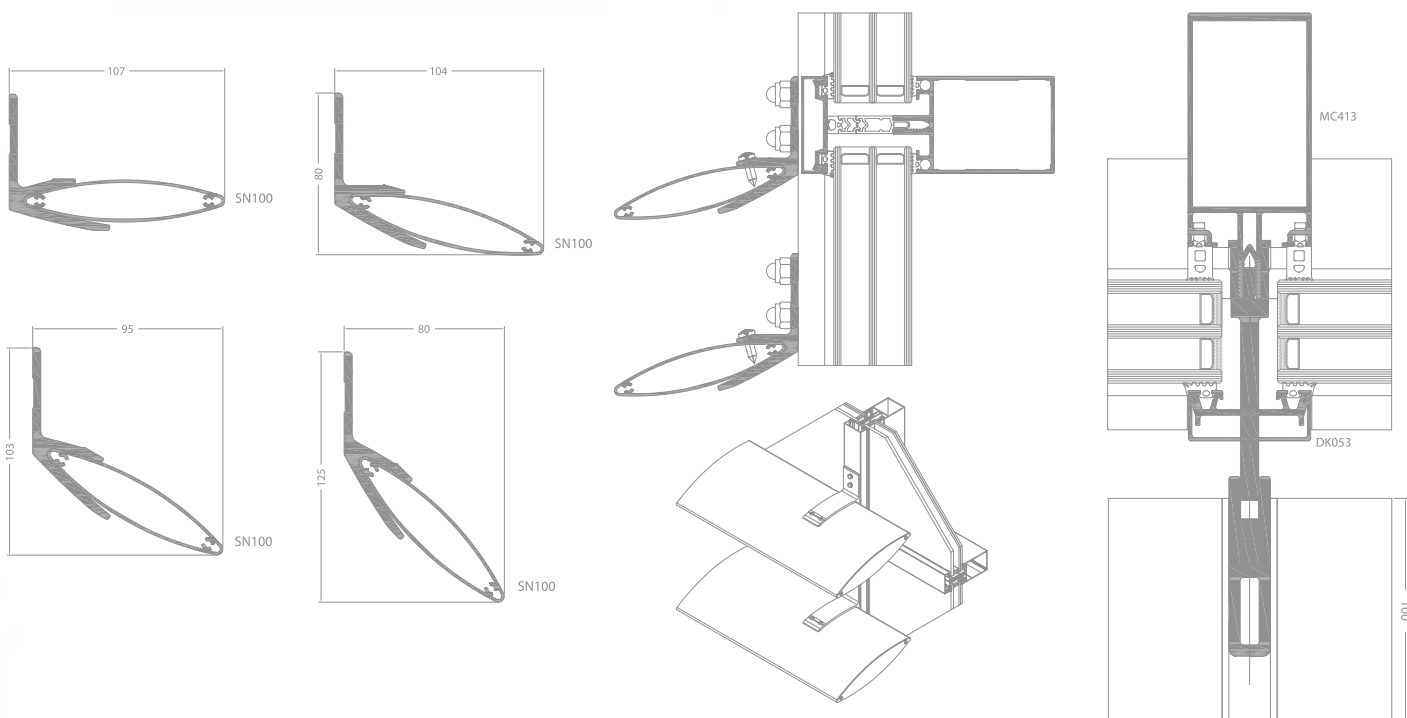

TECHNICAL SPECIFICATION

SYSTEM	MATERIAL	AVAILABLE SIZES	ANGLE OF INCLINATION
SUN PROTECTION	aluminium	100, 150, 158, 200, 250, 270, 300, 350 mm	0°, 14°, 15°, 30°, 45°, 60°, 75°